

Clear-ice®



BOLTLESS WORKSTATION

MODEL NO: CWB450WS

PART NO: 7637882

ASSEMBLY INSTRUCTIONS

GC1016

INTRODUCTION

Thank you for purchasing this CLARKE workstation.

Before attempting to use this product, please read this manual thoroughly and follow the instructions carefully. In doing so you will ensure the safety of yourself and that of others around you, and you can look forward to your purchase giving you long and satisfactory service.

SPECIFICATION

Model	CWB450WS
Dimensions (L x W x H)	1800 x 750 x 1695 mm
Weight	60 kg
Maximum rated load	300 kg/board 100 kg/shelf

UNPACKING

When unpacking, check for damaged or missing parts. Any deficiencies found should be reported to your CLARKE dealer where the product was originally purchased.

Do not dispose of damaged components or packaging with general household waste. They should be taken to a recycling centre and disposed of appropriately. This product should include the items listed on page 4.

SAFETY PRECAUTIONS

1. Always read these instructions before use.
2. Always wear protective gloves when assembling the workstation.
3. It is recommended that the assembly be done by two persons.
4. Not following these instructions could result in the workstation falling over, causing damage to equipment and personal injury.
5. Never carry out any alterations or modifications to this product or use the workstation for a purpose for which it was not intended.
6. Never allow children to climb on the workstation.
7. Always ensure the load is positioned centrally and evenly distributed.
8. If replacing parts, only use those supplied by Clarke International.
9. Do not exceed the maximum rated load as stated on page 2 and on the warning labels.
10. Only use on a flat, level surface capable of supporting the workstation and its maximum load.
11. Always ensure you are working on a firm flat surface and that the workstation is completely stable.
12. Take care when placing a heavy load on to the bench or shelves. It should be placed gently so that the strain is taken up gradually.
13. Always keep the work areas clean and well lit.
14. Check for damaged parts before using the workstation. Any part that appears damaged should be carefully checked to determine that it will perform its intended function. Replace any damaged parts as soon as possible.
15. Always place heavier items on the lower shelf where possible.
16. Always distribute loads evenly across the shelves where possible.
17. These units are not recommended for outdoor use.
18. It is recommended that this workstation be secured to an adjacent wall.
19. Keep these instructions in a safe place for future reference.

INVENTORY

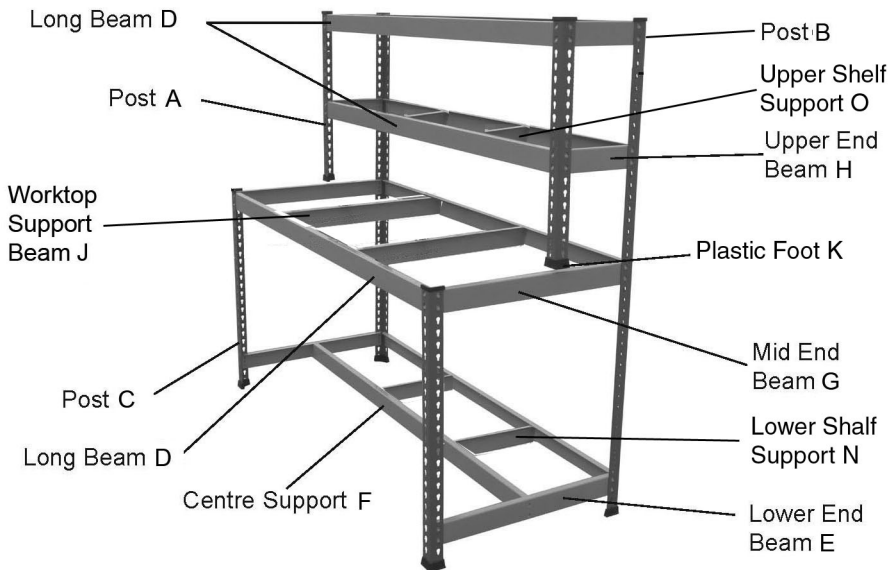

No	Description	Quantity
A	Upper Front Corner Post 786mm	2
B	Rear Corner Post 1684mm	2
C	Lower Front Corner Post 890mm	2
D	Long Support Beam	7
E	Lower End Beam	2
F	Long Lower Shelf Support Beam	1
G	Mid End Beam	2
H	Upper End Beam	4
J	Worktop Support Beam	2
K	Plastic Foot	6
L	Worktop (see picture on front of manual)	1
M	Shelf (see picture on front of manual)	3
N	Lower Shelf Support	2
O	Upper Shelf Support	4

ASSEMBLY

TOOLS REQUIRED

- Rubber mallet or hammer
- Protective cloth/wood block

ASSEMBLY PROCEDURE

1. Assemble on a firm, level surface. Avoid assembly on a domestic carpet.
2. Always ensure that the tabs sit at the bottom of the keyhole slots.
3. It is recommended that the assembly should be done by two persons.

4. Use a cloth or softwood block to protect the surface finish of the product when using a mallet.
5. The tabs of the beams will often enter the slots fully using just firm hand pressure but if they are too tight, you may require a rubber mallet to assist. If so, always use a cloth to protect the product paint finish.

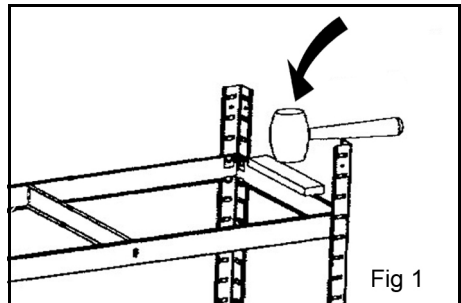

6. Tap gently with the mallet to drive the tabs of the beams fully into the slots in the corner post. Always strike the edge close to the post.
7. Decide how high you want the lower shelf to be, relative to the floor, noting that the lower shelf should never be more than half height from the bottom of the corner posts.

8. Use a mid-end beam (G) and a lower end beam (E) to connect the lower front corner post (C) to the rear corner post (B) as in Fig 1 and create an end assembly.

NOTE: The beam edge with the wider flange should be installed uppermost to support the shelf or worktop.

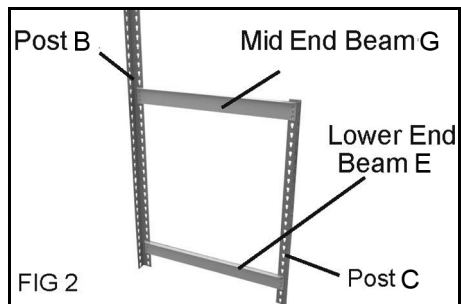

9. Repeat this again for the other end assembly, making sure that the corresponding beams are at the same height.

10. Use the long beams (D) to connect the two end assemblies together as shown in Fig 3.

11. Use the centre support beam (F) to connect the end assemblies together.

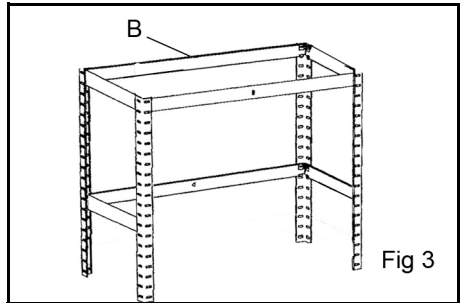

12. Add the worktop support beam (J), bending the flexible tabs to 90 degrees and slotting them into place as shown in Fig 4.

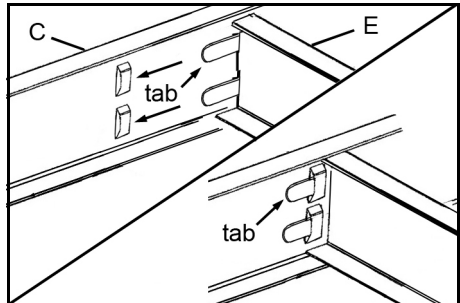

13. Finally bend the tabs back 180 degrees to lock in place.

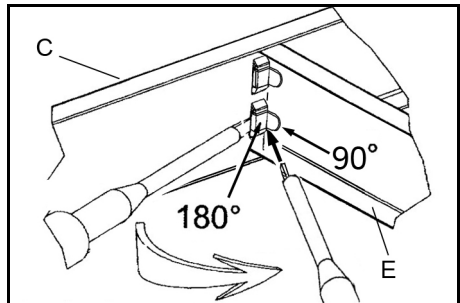

14. Fit the work top (L) in position before continuing to assemble the upper beams in the same way as the lower beams.

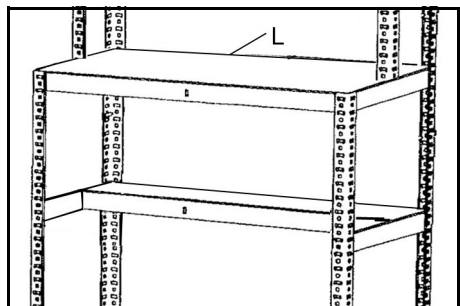

15. Mark the worktop where the upper front corner posts (A) will stand and fix the plastic feet (K) to the worktop with a screw or bolt. Position the upper front corner posts (A) on the plastic feet.

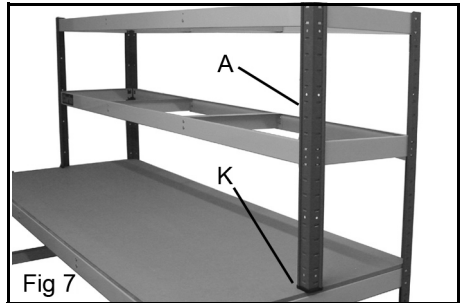

16. Position the workstation on the four plastic feet (H).

17. Position all the remaining shelf panels on the beams.

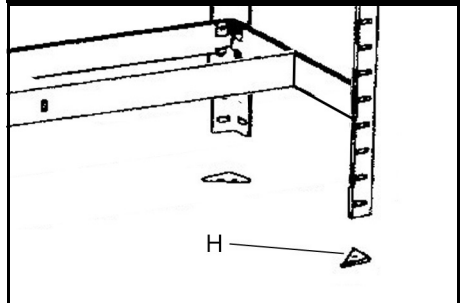

SPARE PARTS

In the event of damage, spare parts are available from the Clarke International parts department.

GUARANTEE

This product is guaranteed against faulty manufacture for a period of 12 months from the date of purchase. Please keep your receipt which will be required as proof of purchase.

This guarantee is invalid if the product is found to have been abused or tampered with in any way, or not used for the purpose for which it was intended.

Faulty goods should be returned to their place of purchase, no product can be returned to us without prior permission.

This guarantee does not effect your statutory rights.

A SELECTION FROM THE VAST RANGE OF

Clarke®

QUALITY PRODUCTS

AIR COMPRESSORS

From DIY to industrial, Plus air tools, spray guns and accessories.

GENERATORS

Prime duty or emergency standby for business, home and leisure.

POWER WASHERS

Hot and cold, electric and engine driven - we have what you need

WELDERS

Mig, Arc, Tig and Spot. From DIY to auto/industrial.

METALWORKING

Drills, grinders and saws for DIY and professional use.

WOODWORKING

Saws, sanders, lathes, mortisers and dust extraction.

HYDRAULICS

Cranes, body repair kits, transmission jacks for all types of workshop use.

WATER PUMPS

Submersible, electric and engine driven for DIY, agriculture and industry.

POWERTOOLS

Angle grinders, cordless drill sets, saws and sanders.

STARTERS/CHARGERS

All sizes for car and commercial use.



PARTS & SERVICE: 0208 988 7400

E-mail: Parts@clarkeinternational.com or Service@clarkeinternational.com

SALES: UK 01992 565333 or Export 00 44 (0)1992 565335

Clarke® INTERNATIONAL Hemnall Street, Epping, Essex CM16 4LG
www.clarkeinternational.com